

# Fourier series and differential equations

Nathan Pflueger

3 December 2014

The flagship application for Fourier series is analysis of differential equations. Indeed, Joseph Fourier was led to introduce the series that now bear his name in studying differential equations that govern the diffusion of heat. Most of the most impressive applications of Fourier series, including heat transmission, require some multivariable calculus, so they are not within our scope for math 19. In this course, we will consider only one specific type of equation, which arises when modeling a damped spring or an electric circuit.

The goal of this note will be to solve one particular differential equation. The methods shown here apply in much broader circumstances, which you will see in other courses.

## 1 How a circuit turns one wave form into another

We will consider the behavior of a very simple electrical circuit: a resistor (resistance  $R$ ), a capacitor (capacitance  $C$ ) and an inductor (inductance  $L$ ) are placed in order, connected by wires (the order of placement turns out not to matter). The two ends are then attached to an alternating current power source, which provides voltage  $V(t)$  at time  $t$ . This circuit can be described by the following circuit diagram.

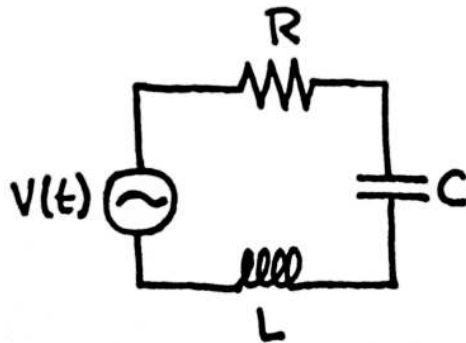

The picture below shows the three components mentioned arranged in sequence (before they are connected to a power source). In this picture, the order is resistor, inductor, capacitor, although as I mentioned the order of the components does not affect the behavior of the circuit.



In earlier homework problems, we have consider the case where  $V(t)$  is simply a constant, which corresponds to *direct current*. In many circuits, however, the incoming power is *alternating current*, which means

that  $V(t)$  is not constant, but instead follows some periodic pattern (typically of fairly high frequency – the period of  $V(t)$  would be about 17 milliseconds for wall current in the United States – we will nonetheless pretend that the period is  $2\pi$  to reduce clutter in the notation).

What happens when this voltage is applied to this circuit? The answer depends on the precise shape of the wave described by  $V(t)$ . One way to describe the behavior of the circuit is to introduce another function  $Q(t)$ , which tells the amount of charge currently stored on the capacitor<sup>1</sup>. The way in which the charge evolves over time is described by the following differential equation.

$$L \cdot Q''(t) + R \cdot Q'(t) + \frac{1}{C}Q(t) = V(t)$$

Typically, we have solved differential equations by first supplying initial conditions to uniquely determine the solution. It turns out that in this case, once you turn the power one and let the circuit run, regardless of the initial conditions, the function  $Q(t)$  will settle down to *one particular function*, which will be periodic (of the same period as  $V(t)$ ). This special solution is called the *steady-state solution*, and identifying it will be the goal of this note.

To be specific, we will consider the following particular case of the differential equation above. This case corresponds to inductance  $L = 1$  Henry, resistance  $R = 1$  Ohm, and capacitance  $C = 0.25$  Farads (for those of you keeping score: these values are not realistic for actual components; once again, I am picking values to keep the calculations simple). I will also take the voltage input to be  $V(t) = \sin t + \cos(2t)$ .

$$Q''(t) + Q(t) + 4Q(t) = \sin t + \cos(2t)$$

The wave form  $V(t) = \sin t + \cos(2t)$  is shown below. This is the input provided to the circuit.

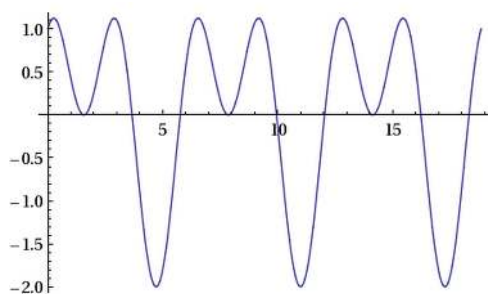

To illustrate the notion of a steady state solution, I have provided below graphs of several particular solutions, for several different sets of initial conditions. As you can see in these plots, these solutions differ only at the beginning – after a short time all of them appear to settle down to the same wave form. All of these images are produced with Wolfram Alpha. Note that some of the figures have been scaled horizontally to fit in the box; in fact each converges to a wave form of the same aptitude.

---

<sup>1</sup>Another good choice for the function to describe the behavior of the circuit is the current through the circuit, usually written  $I(t)$ . I have chosen to work with  $Q(t)$  since it is enough to completely describe the state of the circuit; in fact, the current can be expressed simply as  $Q'(t)$ .

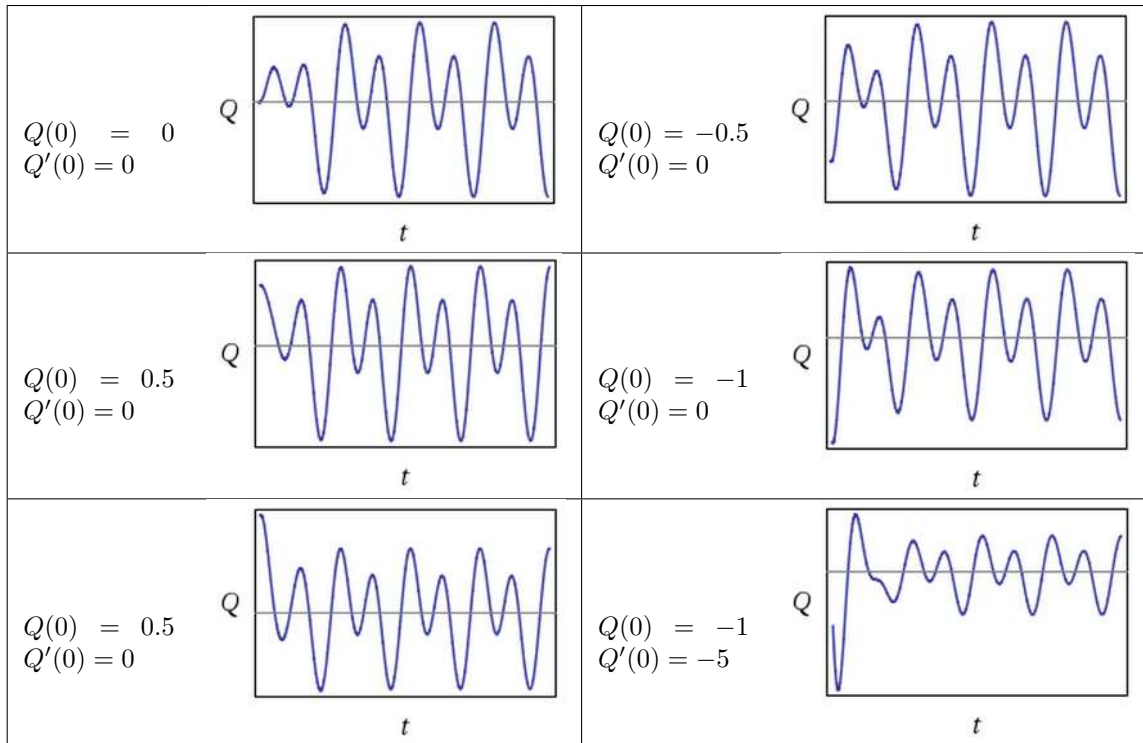

The fact that all these solutions begin differently but settle down to the same long-term behavior suggest the following terminology: the behavior of  $Q(t)$  near  $t = 0$  is called the *transient behavior*, while the wave form that it settled down to after some time is the *steady state*. The steady state does not depend on the initial conditions; it only depends on the wave  $V(t)$  being fed into the circuit.

For this reason, you can think of the circuit as a way of transforming one wave to another. It receives one wave as stimulus (the function  $V(t)$ ) and returns another wave as output (the function  $Q(t)$ ). The following plot shows  $V(t)$  and the steady-state  $Q(t)$  superimposed. Studying this plot gives you sense for how one wave influences, and leads to, the other.

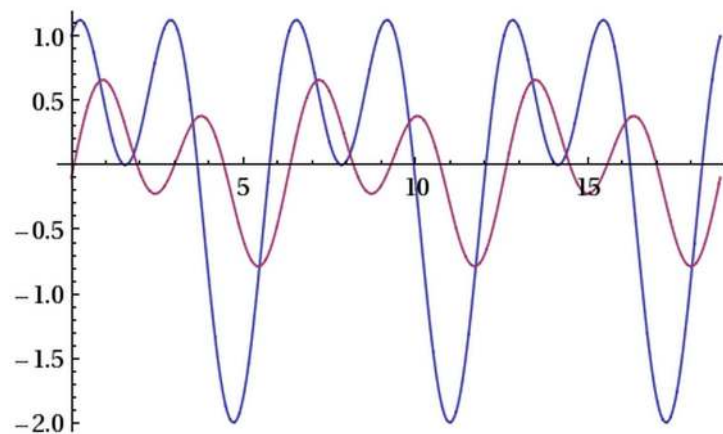

As you can see in this picture, the red curve ( $Q(t)$ ) resembles the blue curve in certain ways, but differs in others. In particular, it has the same pattern of local maxima and minima, but there is a slight delay, and the curve has also been skewed downward. Behavior like this occurs in many other physical phenomenon, especially when a structure (a bridge or a building) sways in some periodic way in response to stimulus

(which might be wind, or cars driving over it, or an earthquake). The stimulus (here, the voltage function  $V(t)$ ) is sometimes called the *forcing function*, and the goal is to determine how the forcing function induces the behavior of the result. Especially important in engineering applications is learning whether there are particularly dangerous frequencies – resonant frequencies – which will induce a much more violent response in the system than others.

You can view the simple electrical circuit that we are studying as a physical way to transform one wave form (that of  $V(t)$ ) into another. The goal of this note is to show how Fourier series can shed led on the precise nature of this transformation. I will finish with a brief discussion of resonant frequencies and how this type of analysis can sniff them out, although this discussion will not be part of the official course.

## 2 The problem and solution strategy

Formally speaking, the mathematical problem at hand is to solve the following differential equation.

$$Q''(t) + Q'(t) + 4Q(t) = \sin t + \cos(2t)$$

As we've seen, there are infinitely many solutions, which are usually distinguished by initial conditions. This time, though, we will not require an initial condition, but instead the condition that  $Q(t)$  is *periodic*. Formally, we could express this condition by writing the following.

$$Q(t + 2\pi) = Q(t)$$

In the terms of the previous section: we want the *steady-state* solution of this differential equation. This is the function that every solution, regardless of initial conditions, will settle to over time.

The solution strategy will following several steps.

1. Convert the voltage function  $V(t) = \sin t + \cos(2t)$  to a *complex* Fourier series. That is, compute the complex Fourier coefficients  $c_n(V)$ .
2. Write the coefficients  $c_n(Q)$  of  $Q(t)$  in terms of the coefficients of  $V(t)$ .
3. Write down the complex Fourier series of  $Q(t)$ .
4. Convert this complex Fourier series to a real Fourier series.

This strategy is very typical of the use of complex numbers – they serve an intermediate role in computations but are ultimately filtered out in the final result. The crucial part, where complex number really shine as a labor-saving device, is step 2, which will be explained in the next section. Step 2 also provides a window into how you would go about computing resonant frequencies of the circuit, as I will explain in the optional appendix.

## 3 Fourier coefficients and derivatives

The potency of complex Fourier coefficients in analyzing differential equations stems from the following very simple formula, which expresses the complex Fourier coefficients of the derivative  $f'(x)$  in terms of those of  $f(x)$ . As long as  $f(x)$  is a *periodic and continuous* function, the following relation holds.

$$\boxed{c_n(f') = in \cdot c_n(f)}$$

There are several ways to remember this formula. Probably the simplest is to observe that the derivative of  $e^{inx}$  is  $ine^{inx}$ . Therefore if

$$f(x) = \sum_{n=-\infty}^{\infty} c_n e^{inx}$$

then

$$f'(x) = \sum_{n=-\infty}^{\infty} c_n \cdot in \cdot e^{inx}.$$

If  $f(x)$  is not continuous (or not periodic), it may not be exactly equal to the sum of its Fourier series, but a similar formula holds with some correction terms. This situation is frequently useful in the study of electricity and magnetism, but we will not dwell on it here.

How does this equation help solve the differential equation at hand? Notice that if we take the Fourier coefficients of both sides of the equation  $Q''(t) + Q'(t) + 4Q(t) = V(t)$ , we can solve for the Fourier coefficients of  $Q$ , as follows. For any integer  $n$  (positive or negative):

$$\begin{aligned} Q'' + Q' + 4Q &= V \\ c_n(Q'') + c_n(Q') + c_n(4Q) &= c_n(V) \\ (in)^2 c_n(Q) + (in)c_n(Q) + 4c_n(Q) &= c_n(V) \\ c_n(Q) &= \frac{1}{(in)^2 + in + 4} c_n(V) \end{aligned}$$

This equation is the lynchpin in the solution of our problem.

## 4 Solving the problem

We will now solve the problem following the four steps outlines in section 2.

**Step 1.** Convert  $V(t) = \sin(t) + \cos(2t)$  to a complex Fourier series.

This step requires expanding the trigonometric functions into pairs of complex exponential functions, as discussed in the previous note.

$$\begin{aligned} V(t) &= \frac{i}{2} (e^{-it} - e^{it}) + \frac{1}{2} (e^{-2it} + e^{2it}) \\ &= \frac{1}{2} e^{-2it} + \frac{i}{2} e^{-it} - \frac{i}{2} e^{it} + \frac{1}{2} e^{2it} \end{aligned}$$

Therefore the complex Fourier coefficients of  $V(t)$  are as follows.

$$\begin{aligned} c_{-2} &= \frac{1}{2} \\ c_{-1} &= \frac{i}{2} \\ c_1 &= -\frac{i}{2} \\ c_2 &= \frac{1}{2} \\ \text{all other } c_n &= 0 \end{aligned}$$

**Step 2.** Write the coefficients  $c_n(Q)$  in terms of  $c_n(V)$ .

Here we use the fact discussed in the previous section to deduce that for all  $n$ ,

$$\begin{aligned} [(in)^2 + (in) + 4] c_n(Q) &= c_n(V) \\ c_n(Q) &= \frac{1}{(in)^2 + (in) + 4} c_n(V). \end{aligned}$$

This equation now makes it possible to find the complex Fourier coefficients of  $Q(t)$ , using the result of the previous step.

$$\begin{aligned}
 c_{-2}(Q) &= \frac{1}{(-2i)^2 - 2i + 4} \cdot \frac{1}{2} \\
 &= \frac{1}{-4 - 2i + 4} \cdot \frac{1}{2} \\
 &= \frac{1}{-4i} \\
 &= \frac{i}{4}
 \end{aligned}$$

$$\begin{aligned}
 c_{-1}(Q) &= \frac{1}{(-i)^2 - i + 4} \cdot \frac{i}{2} \\
 &= \frac{i}{(3 - i)2} \\
 &= \frac{i(3 + i)}{(3 - i)(3 + i)2} \\
 &= \frac{3i - 1}{20} \\
 &= -\frac{1}{20} + \frac{3}{20}i
 \end{aligned}$$

$$\begin{aligned}
 c_1(Q) &= \frac{1}{i^2 + i + 4} \cdot \left(-\frac{i}{2}\right) \\
 &= \frac{-i}{(3 + i)2} \\
 &= \frac{-i(3 - i)}{(3 + i)(3 - i)2} \\
 &= \frac{-3i - 1}{20} \\
 &= -\frac{1}{20} - \frac{3}{20}i
 \end{aligned}$$

$$\begin{aligned}
 c_2(Q) &= \frac{1}{(2i)^2 + 2i + 4} \cdot \frac{1}{2} \\
 &= \frac{1}{2i \cdot 2} \\
 &= -\frac{i}{4}
 \end{aligned}$$

These are the nonzero Fourier coefficients. All the rest are 0, since all the rest of the coefficients of  $V(t)$  are zero.

*Note.* It may not have escaped your notice that when we are discussing real functions, it is always the case that  $c_{-n}$  is the complex conjugate of  $c_n$ . Therefore you can actually cut your work in half and just find  $c_1$  and  $c_2$  (or  $c_{-1}$  and  $c_{-2}$ ).

**Step 3.** Write down the complex Fourier series of  $Q(t)$ .

Now that we have the Fourier coefficients of  $Q(t)$ , we can write down a (complex) expression for it.

$$Q(t) = \frac{i}{4}e^{-2it} + \left(-\frac{1}{20} + \frac{3}{20}i\right)e^{-it} + \left(-\frac{1}{20} - \frac{3}{20}i\right)e^{it} - \frac{i}{4}e^{2it}$$

**Step 4.** Convert this complex Fourier series to a real Fourier series.

As described in the previous note, there are a couple ways to go about this last step. I will follow below the second method presented there.

$$\begin{aligned} Q(t) &= -\frac{1}{20}(e^{-it} + e^{it}) + \frac{3}{20}i(e^{-it} - e^{it}) + \frac{i}{4}(e^{-2it} - e^{2it}) \\ &= -\frac{1}{20} \cdot 2 \cos t + \frac{3}{20} \cdot 2 \sin t + \frac{1}{4} \cdot 2 \sin(2t) \\ &= -\frac{1}{10} \cos t + \frac{3}{10} \sin t + \frac{1}{2} \sin(2t) \end{aligned}$$

Therefore the steady-state solution to the equation  $Q''(t) + Q'(t) + 4Q(t) = \sin t + \cos(2t)$  is the following.

$$Q(t) = -\frac{1}{10} \cos t + \frac{3}{10} \sin t + \frac{1}{2} \sin(2t)$$

*Remark.* There are a number of ways to save labor in the conversions of steps 1 and 4 between real and complex Fourier series. In particular, you can read the coefficients  $a_n$  and  $b_n$  from the real and imaginary parts of  $c_n$  (up to some constants). For time reasons, I have chosen not to go too deeply into these techniques. However, I certainly encourage you to look for these shortcuts, and you are free to use them.

## Appendix: finding the resonant frequency

This appendix is not part of the course proper, and will not appear on the homework or exam. I include it for any students interested in seeing how the analysis in this note leads quickly into deeper themes.

The key insight in all this analysis was the formula that links the complex Fourier coefficients of  $Q(t)$  to those of  $V(t)$ .

$$c_n(Q) = \frac{1}{(in)^2 + in + 4} c_n(V)$$

Two features may leap out at you from this formula.

1. The closer this denominator,  $[(in)^2 + in + 4]$ , is to 0, the greater the magnification will occur at frequency  $n$ .
2. This denominator is precisely  $p(in)$ , where  $p(\lambda)$  is the characteristic polynomial  $\lambda^2 + \lambda + 4$  of the homogeneous differential equation  $Q'' + Q' + 4Q = 0$ , in the terminology of our earlier study of differential equations.

This has a very important consequence: the closer that the imaginary number  $in$  is to the places where this characteristic polynomial is equal to 0, the smaller this denominator will be, and therefore the greater will be the magnification of the frequency  $n$ .

One often speaks about the *resonant frequencies* of a circuit (or a physical structure): these are the frequencies such that stimulus at that frequency is magnified more than at any other frequency. These

frequencies can be dangerous (e.g. if we are talking about a bridge that may wobble dangerously under certain conditions), or they can be desirable (e.g. a radio will want to amplify the frequency to which it is tuned more than others).

What we have seen above is that the resonant frequencies of an object whose behavior is described by a differential equation like the one we consider in this document are encoded by the complex numbers where the characteristic polynomial is equal to 0. This explains a bit of terminology: the places where this polynomial is 0 (which are complex numbers in general) are called the *spectrum* of the differential equation. The spectrum gives a way to encode which frequencies will resonate the most.

In the case of our differential equation, the characteristic polynomial is  $\lambda^2 + \lambda + 4$ , which has two complex roots  $\lambda = -\frac{1}{2} \pm \frac{\sqrt{15}}{2} \approx 0.5 \pm 1.936i$ . These two complex numbers constitute the spectrum. Notice that in the solution we found to the differential equation in question, the frequency 2 was magnified somewhat more than frequency 1 – that is because  $2i$  lies closer to the points of this spectrum than  $i$  does. Frequency 2 is more resonant.

One caveat: how small the complex number  $p(\lambda)$  depends on more than just how close  $\lambda$  is to one of the places where  $p(\lambda) = 0$ ; the most resonant frequencies are not necessarily the values of  $n$  where  $in$  is closest (in terms of distance) to a point in the spectrum. But these values of  $n$  will certainly be close to the zeros, so looking for points closest to elements of the spectrum is a good first approximation. You could find the resonant frequencies exactly by minimizing the function  $|p(ix)|^2$  for real values of  $x$  (this will be a polynomial in  $x$ ).